

1106A-70TAG2

163.8 kWm (Gross) @ 1800rpm

Electropak

1100

Series

Basic technical data

Number of cylinders	6
Cylinder arrangement	In-line
Cycle	4 stroke
Induction system	Turbocharged and air charge cooled
Combustion system	Direct injection diesel
Compression ratio	16:1
Bore	105 mm
Stroke	135 mm
Cubic capacity	7.01 litres
Direction of rotation	Anticlockwise when viewed from flywheel
Firing order	1, 5, 3, 6, 2, 4
Estimated total weight (dry)	788 kg
Estimated total weight (wet)	822 kg

Overall dimensions, Electropak

Height	1142 mm
Length (air cleaner fitted)	1763 mm
Width	756 mm

Moments of inertia

Engine rotational components	0.27 kgm ²
Flywheel	1.26 kgm ²

Centre of gravity, Electropak

Forward from rear of block (wet)	476 mm
Above crankshaft centre line (wet)	176 mm
Offset to RHS of crankshaft centre line (wet)	16 mm

Performance

Speed variation at constant load	± 0.25%
Cyclic irregularity at standby power	0.028
All ratings within	± 5%

Note: All data based on operation to ISO 3046-1:2002 standard reference conditions.

Sound level

Average sound pressure level for Prime Power @ 1 m TBA dB(A)

Test conditions

Air temperature	25°C
Barometric pressure	100 kPa
Relative humidity	31.5%
Air inlet restriction at maximum power	3 kPa (maximum)
Exhaust back pressure at maximum power	6 kPa (maximum)
Fuel temperature	45°C

Note: If the engine is to operate in ambient conditions other than those of the test conditions, suitable adjustments must be made for these changes. For full details, contact Perkins Technical Service Department.

General installation

General Installation	Units	Prime	Standby
Gross engine power	kW	155.4	171.8
Gross BMEP	kPa	1477.9	1633.9
Mean piston speed	metres/s	8.1	
ElectropaK net engine power	kW	147.4	163.8
Engine coolant flow (against 35 kPa restriction)	litres/min	170	
Combustion air flow (at STP)	m ³ /min	15.12	14.84
Exhaust gas flow (Max.)	m ³ /min	31.87	32.2
Exhaust gas temperature (Max.) in manifold (after turbocharger)	°C	407	
Net engine thermal efficiency	%	37.32	38.06
Typical genset electrical output (0.8pf 25°C)	kWe	135	150
	kVA	168.8	187.5
Regenerative power (estimated)	kW	7.8	
Assumed alternator efficiency	%	91.6	

Rating definitions

Prime power

Unlimited hours usage, with an average load factor of 80% over each 24 hour period. A 10% overload is available for 1 hour in every 12 hours operation.

Standby power

Limited to 500 hours annual usage, with an average load factor of 80% of the published Standby power rating over each 24 hour period. Up to 300 hours of annual usage may be run continuously. No overload is permitted on standby power.

Energy balance

Designation	Units	Prime	Standby
Heat in fuel	kW	395	430.4
Power to cooling fan	kW	8	
Power to coolant and lubricating oil	kW	75.3	81.6
Power to exhaust	kW	113.9	123.2
Energy to charge coolers	kW	31.1	33.5
Power to radiation	kW	11.3	12.3

Note: Not to be used for CHP design purposes (indicative figures only). Consult Perkins Engines Company Limited. Assumes complete combustion.

Cooling system

Cooling pack

Overall weight (wet)	70 kg
Overall face area.....	524800 mm ²
Width	724 mm
Height	1090 mm

Radiator

Face area	351200 mm ²
Number of rows and materials	4 rows, Aluminium
Matrix density and material	10 fins per inch, Aluminium
Width of matrix.....	439 mm
Height of matrix.....	800 mm
Pressure cap setting (Min.)	100 kPa

Charge cooler

Face area	173,600 mm ²
Number of rows and materials	2 rows, Aluminium
Matrix density and material	10 fins per inch, Aluminium
Width of matrix.....	220 mm
Height of matrix.....	789 mm

Fan

Diameter	610 mm
Drive ratio	1,2:1
Number of blades.....	7
Material.....	Nylon
Type	Pusher
Air flow @ 1800 rpm.....	4.94kg/s
Power @ 1800 rpm	8 kW

Coolant

Total system capacity.....	21 litres
System drawdown capacity	10%
Engine capacity	9.5 litres
Maximum top tank temperature	110°C
Temperature rise across engine (Max. rating dependent).....	6°C - 12°C
Max. permissible external system resistance.....	35 kPa
Thermostat operation range	82°C to 93°C
Shutdown switch setting	118°C
Coolant pump method of drive	Gear
Recommended coolant immersion heater rating (Min.)	0.75 kW
Recommended coolant	BS6580 - 1992, ASTM D3306 and ELC coolants to 1E1966

Duct allowance

Maximum additional restriction (duct allowance to cooling airflow and resultant minimum air flow) - Standby power

Description	rpm	kPa	kg/s
Duct allowance with inhibited coolant at 53°C			
Minimum air flow	1800	0.12	4.46
Duct allowance with inhibited coolant at 46°C			
Minimum air flow	1800	0.200	4.09

Electrical system

Alternator	A115i
Alternator voltage.....	12 volts
Alternator output	85 amps
Starter	AZF
Starter motor voltage	12 volts
Starter motor power	4.2 kW
Number of teeth on the flywheel	126
Pull-in current of starter motor solenoid @ -25°C Max. ⁽¹⁾	pulse signal 12 volts 68 amps
Hold-in current of starter motor solenoid @ 0°C Max. ⁽¹⁾	pulse signal 12 volts 20 amps
Engine stop method	Solenoid

¹ All leads to rated at 10 amps minimum

Cold start recommendations

Minimum required cranking speed over TDC..... 60 rpm

	5 to -10°C	-10 to -20°C	-20 to -25°C
Oil	15W40	10W40	5W40
Starter	AZF		
Battery	2x 900CCA		
Max. breakaway current	1020 amps		
Cranking current	960		
Aids	None	Glowplugs	
Minimum mean cranking speed	100 rpm	110 rpm	120 rpm

Note: Battery capacity is defined by the 20 hour rate.

Note: If a change to a low viscosity oil is made, the cranking torque necessary at low ambient temperatures is much reduced. The starting equipment has been selected to take advantage of this. It is important to change to the appropriate multigrade oil in anticipation of operating in low ambient temperatures.

Note: Breakaway current is dependent on battery capacity available. Cables should be capable of handling the transient current which may be up to double the steady cranking current.

Exhaust system

Maximum back pressure - 1500 rpm	6.0 kPa
Exhaust outlet, internal diameter	72 mm

Fuel system

Injection components

Injector Mechanical
 Fuel pump..... DP210G

Fuel priming

Priming pump type Manual
 Maximum priming time..... 90 seconds

Fuel feed

Maximum fuel flow 135 litres/min
 Maximum suction head at engine fuel pump inlet..... 10 kPa
 Maximum static pressure head 10 kPa
 Fuel temperature at engine fuel pump inlet..... 46°C
 Tolerance on fuel consumption ± 5%

Fuel specification

Fuel standard..... Various (contact Perkins Technical Department)

Fuel consumption

Load	Type of operation and application	
	g/kWh	litres/hr
110% Prime power	203.1	41.7
Prime power	205.1	38.2
75% Prime power	208.4	29.1
50% Prime power	202.1	19.1
25% Prime power	232.9	11

Induction system

Maximum air intake restriction

Clean filter 2 kPa
 Dirty filter..... 3 kPa
 Air filter type..... paper element

Lubrication system

Maximum total system oil capacity 16.5 litres
 Minimum oil capacity in sump 12.4 litres
 Maximum oil capacity in sump 14.9 litres
 Maximum engine operating angles -
 Front up, front down, right side, left side..... 25°
 Sump drain plug tapping size 3/4 - 16 UNF
 Shutdown switch setting (where fitted)
 Oil pressure shut down switch 90 kPa Falling

Lubricating oil

Relief valve opening pressure 430 kPa
 Pressure at maximum speed 340 kPa
 Maximum continuous oil temperature (in rail)..... 125°C
 Oil consumption at full load (% of fuel) < 0.1

Recommended SAE viscosity

A multigrade oil must be used which conforms to API CH4 or CI4
 ACEA E5 must be used, see illustration below:

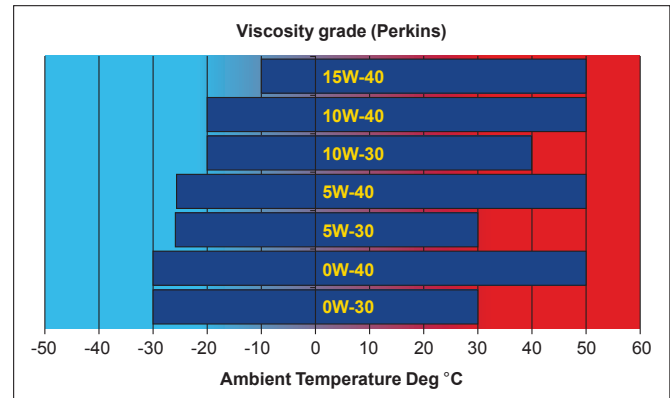

Mountings

Maximum static bending moment at rear face of block..... 1130 Nm
 Maximum permissible overhung load
 on the flywheel..... Calculated on request
 Maximum bending moment at rear of flywheel housing..... ± 3000 in Shock Nm

Load acceptance

The data below complies with the requirements of classification 3 and 4 of ISO 8528-12 and G2 operating limits stated in ISO 8528-5.

Initial load application: When engine reaches rated speed (15 seconds maximum after engine starts to crank).

Description	Units	
%of prime power	%	
Load	kWe	
Transient frequency deviation	%	
Frequency recovery time	Seconds	

Noise data

Noise levels

Position	Noise level dB(A)	
	Prime power	Standby
1	99.9	99.9
2	100.0	101.0
3	100.9	101.2
4	99.8	101.0
5	101.0	101.0
6	100.0	99.9

Noise reference level 65 dB(A)

$\frac{1}{3}$ octave analysis: TBC

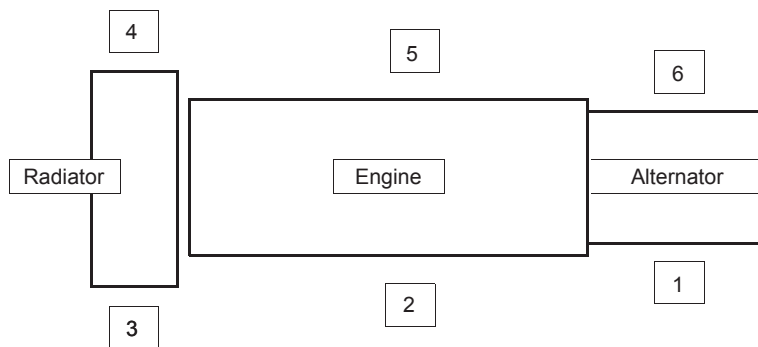

1106A-70TAG2 - Left side view

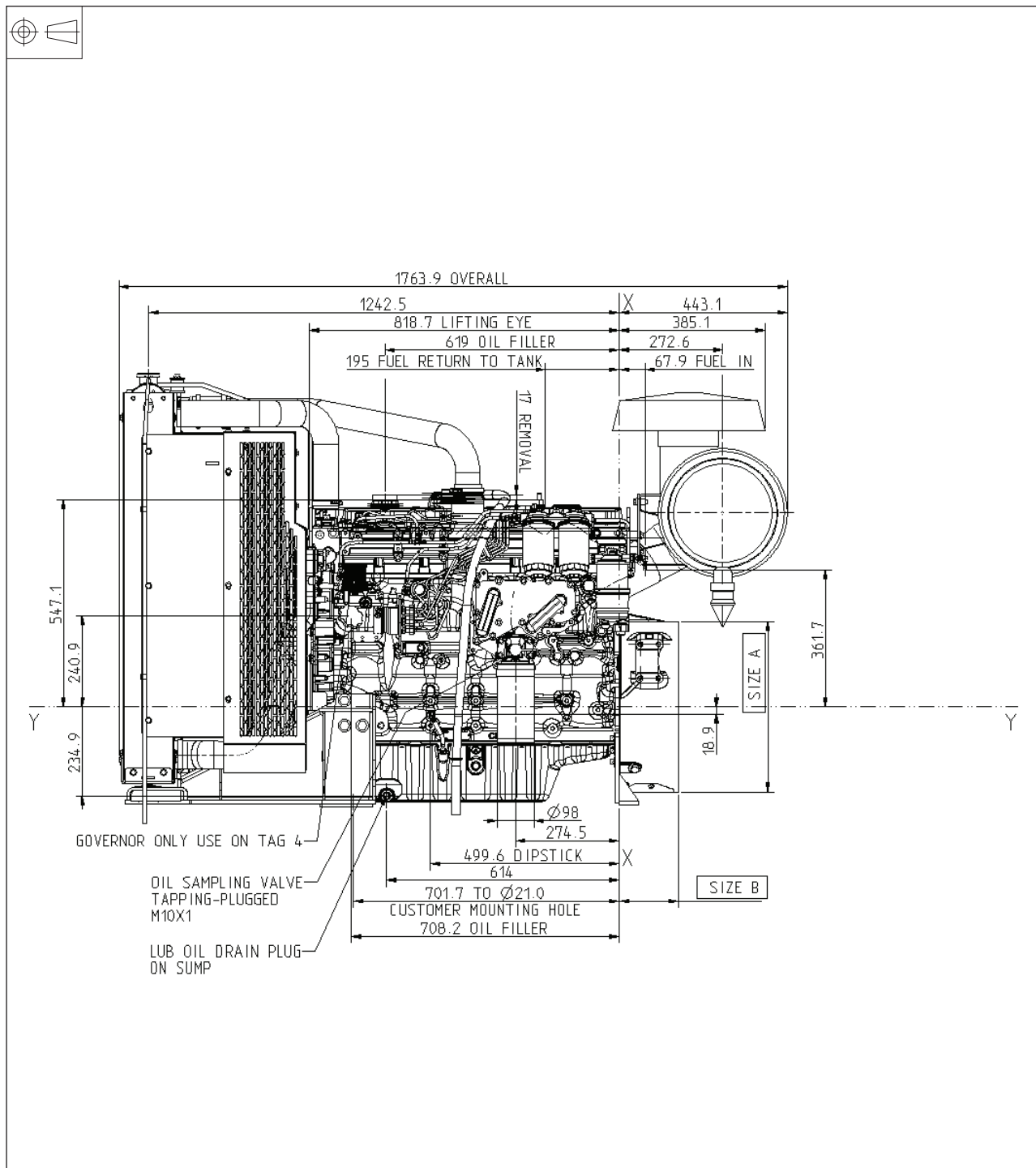

Flywheel and housing options

Option	Part	Size A	Size B	Description
1	C0001 & D0004	ø 450.9	153.37	The type is SAE 2 Use on TAG 2 & 4
2	C0074 & D0090	ø 489	134.6	The type is SAE 3 Use on TAG 3 & 4

1106A-70TAG2 - Front view

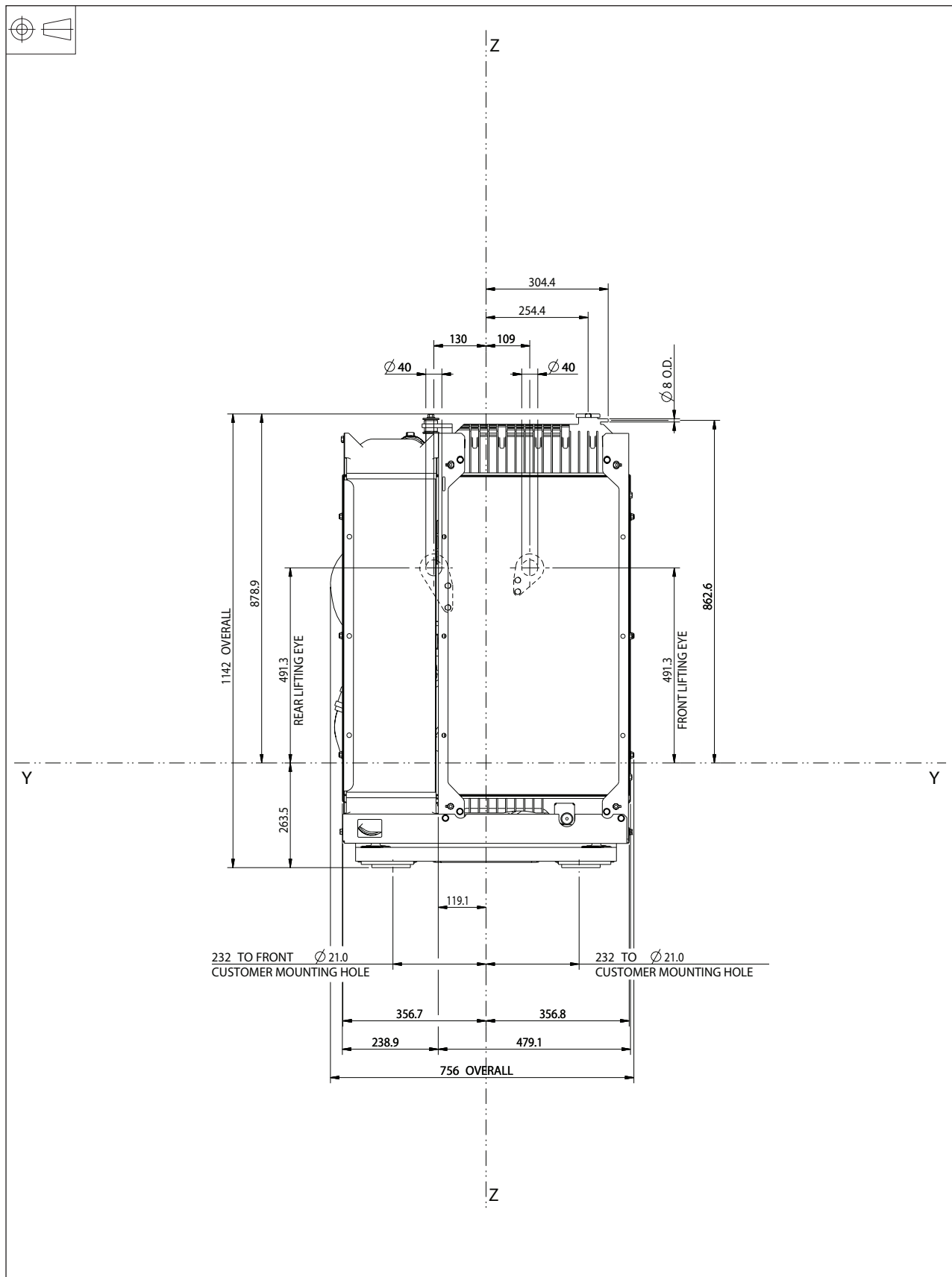

1106A-70TAG2 - Right side view

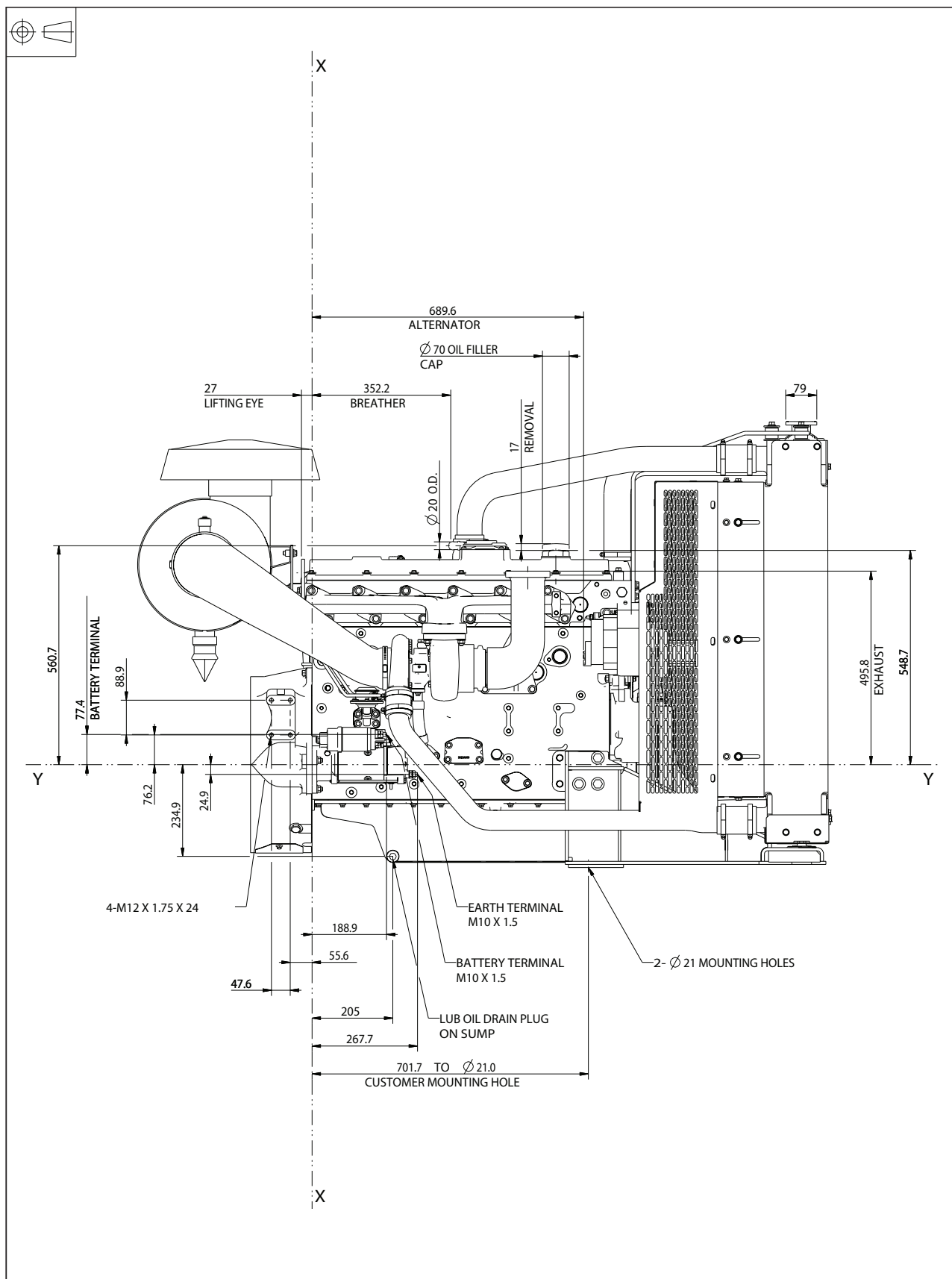

1106A-70TAG2 - Rear view

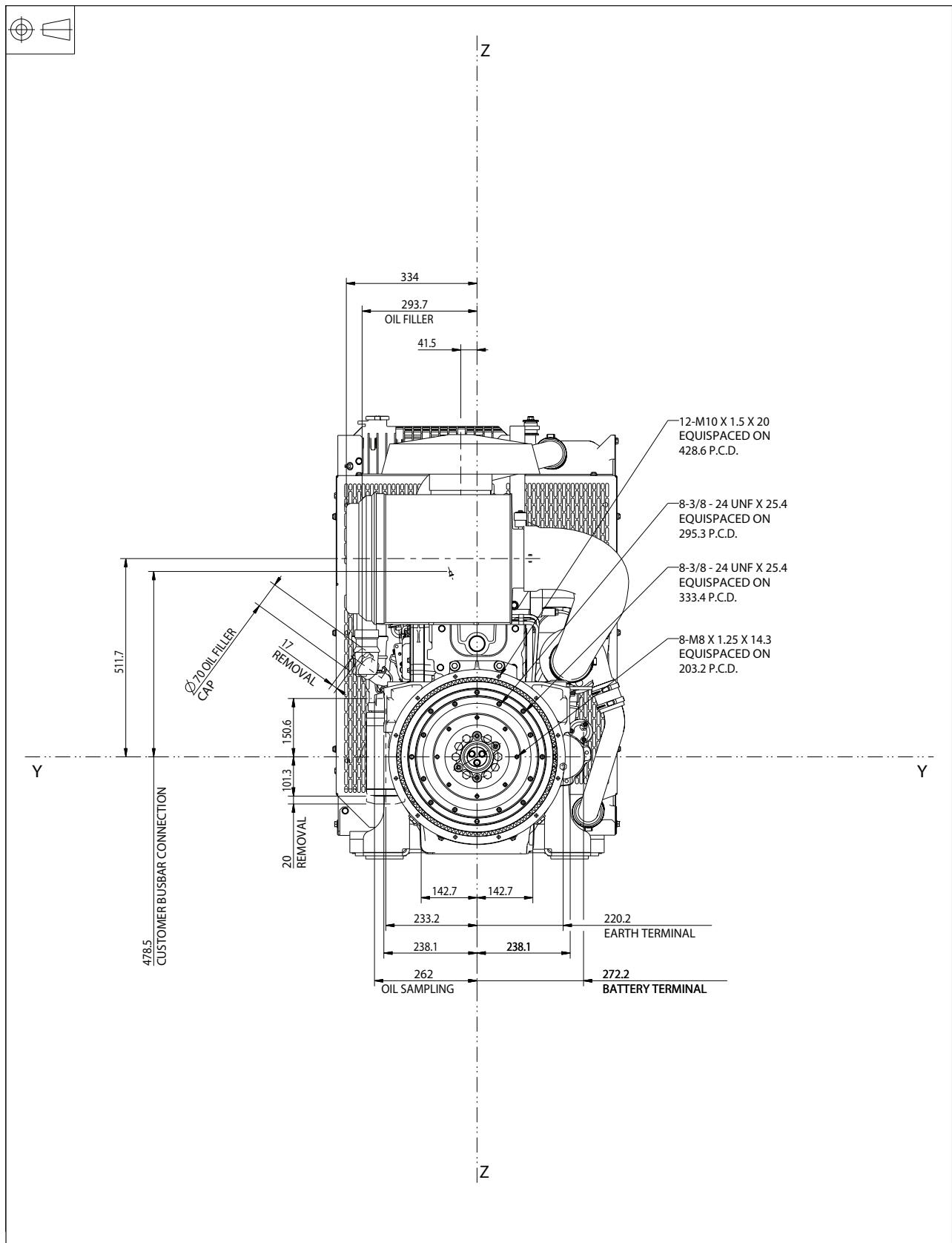

1106A-70TAG2 - Plan view

